



NEW
IMPROVED RELIABILITY
IMPROVED TOTAL SYSTEM ACCURACY
6 YEAR WARRANTY

**HIGH RELIABILITY
MULTI-CHANNEL SIGNAL CONDITIONER
FOR TRANSFORMER APPLICATIONS**

Use with Opsens' GaAs (SCBG) fiber optic temperature sensors

Key Features

- Up to 15 measurement channels
- High linearity and precision
- Improved system accuracy ($\pm 0.8\text{ }^{\circ}\text{C}$)
- Internal reference to guaranty reliability
- Traceable calibration
- Large LCD screen display
- RS-232 and RS-485 serial output with SCPI and ModBus protocol
- Relays and analog output available options
- Available in wall mount version
- 6 year warranty

Applications

- Power Transformer hot spot temperature monitoring
- Multi-point long-term monitoring
- In-situ process monitoring
- High voltage environments
- EMI, RFI and microwave environments
- Nuclear and hazardous environments

Description

At the heart of the PowerSens II is the Opsens' Semiconductor Band Gap (SCBG) technology which provides accurate measurements using the temperature dependent bandgap shift of a GaAs crystal.

The PowerSens II is now fitted with an internal reference that allows regular self verification and correction of its fully traceable calibration. The internal reference guarantees long term Total System Accuracy of 0.8°C in the most adverse conditions encountered in a transformer environment such as temperature variations, component aging, mechanical shocks and transformer vibrations.

The PowerSens II is equipped with LCD display* and SCPI and Modbus communication protocol capability over RS-232 or RS-485 interface. SPDT-type relays and analog outputs (one per optical channel), are optionally available. PLC controller is also available to offer extended control capabilities through a wide range of input/outputs.

The PowerSens II is a multi-channel signal conditioner compatible with any of Opsens' GaAs (SCBG) based fiber optic temperature sensors. The PowerSens II has a channel sampling rate of 50 Hz and channel scanning rate of up to 6.25 Hz. It is used with our standard 62.5/125 micron optical fiber temperature sensors (see for example Opsens OTG-T /OTG-T+ sensor models). A version is also available for 200/230 micron optical fiber sensor models.

*Display not available for 15-channel model.

Opsens

2014 Cyrille-Duquet Street
Suite 125
Quebec City QC
G1N 4N6 Canada

☎ 1.418.682.9996
☎ 1.418.682.9939
✉ Info@opsens.com
www.opsens.com

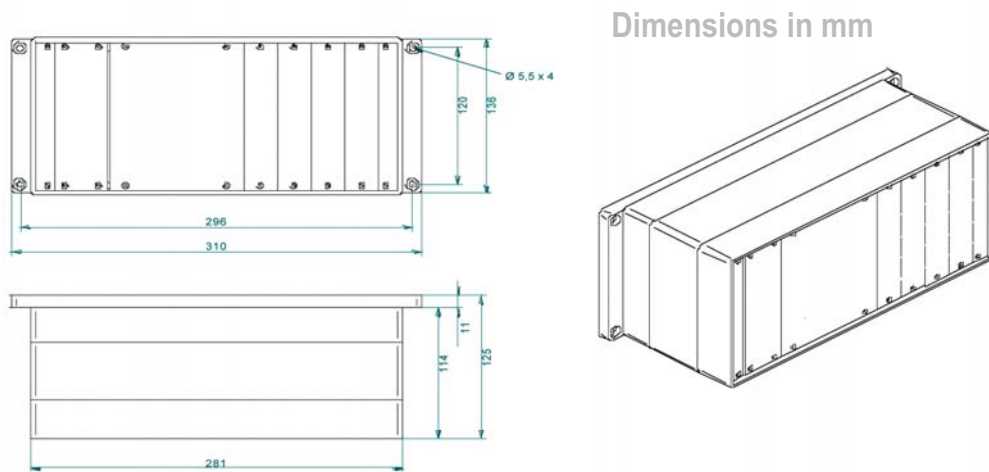

Specifications

Number of channels	3, 6, 9, 12, and 15
Compatibility	All Opsens GaAs fiber optic sensors with 62.5/125 microns optical fiber (200/230 microns optical fiber version available on demand)
Accuracy	± 0.8 °C (Total system accuracy over the full range including both signal conditioner and sensor errors – higher accuracy available on demand)
Resolution	0.1 °C
Reliability	Internal reference
Sampling rate	50 Hz standard (rate given for a fixed channel)
Channel scanning rate	6.25 Hz maximum (channel-to-channel scan period = 160 ms)
Display	LCD screen display standard (not available on 15-channel model)
Serial output interface	RS-232 and RS-485 standard, SCPI and Modbus protocol supported
Analog output	± 5 V, 4-20 mA output, 0-1 mA
Relay	C-Form SPDT relays, 4 A @ 240 VAC or 30 VDC optionally available
Input power	12 to 24 VDC (AC/DC wall-transformer adapter included)
Consumption	2.5 W typical
Storage temperature	-40 °C to 70 °C
Operating temperature	-40 °C to 60 °C (LCD display may not work at all temperature)
Humidity	95 % non condensing
Light source life span	> 25 years MTBF
I/O and control option	PLC controller unit with various I/O optionally available

All specifications are subject to change without prior notification